

YORK Survey Supply



Concrete Test Hammer



Code: 911000

Operating Instructions

$S^2 = 0,959$

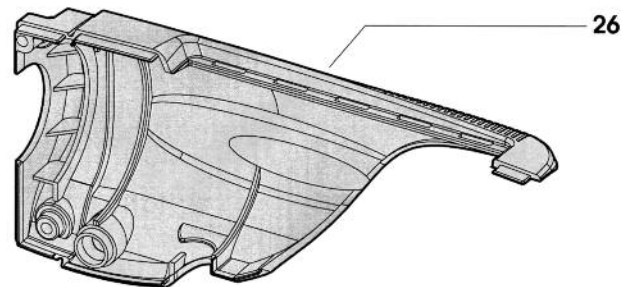
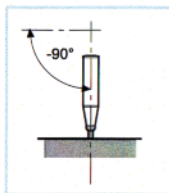
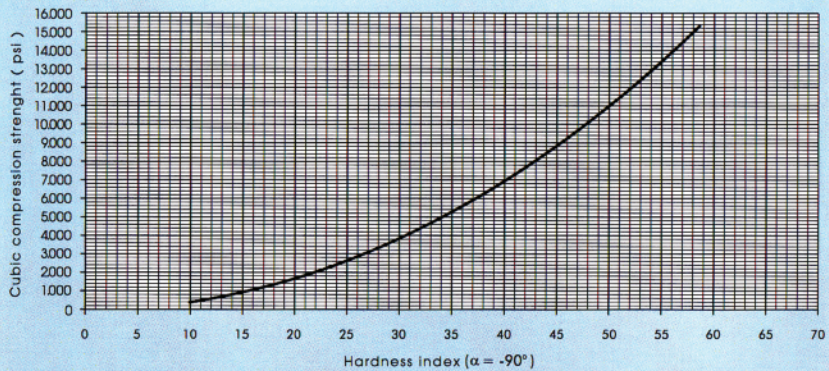

$S^2 = 0,956$

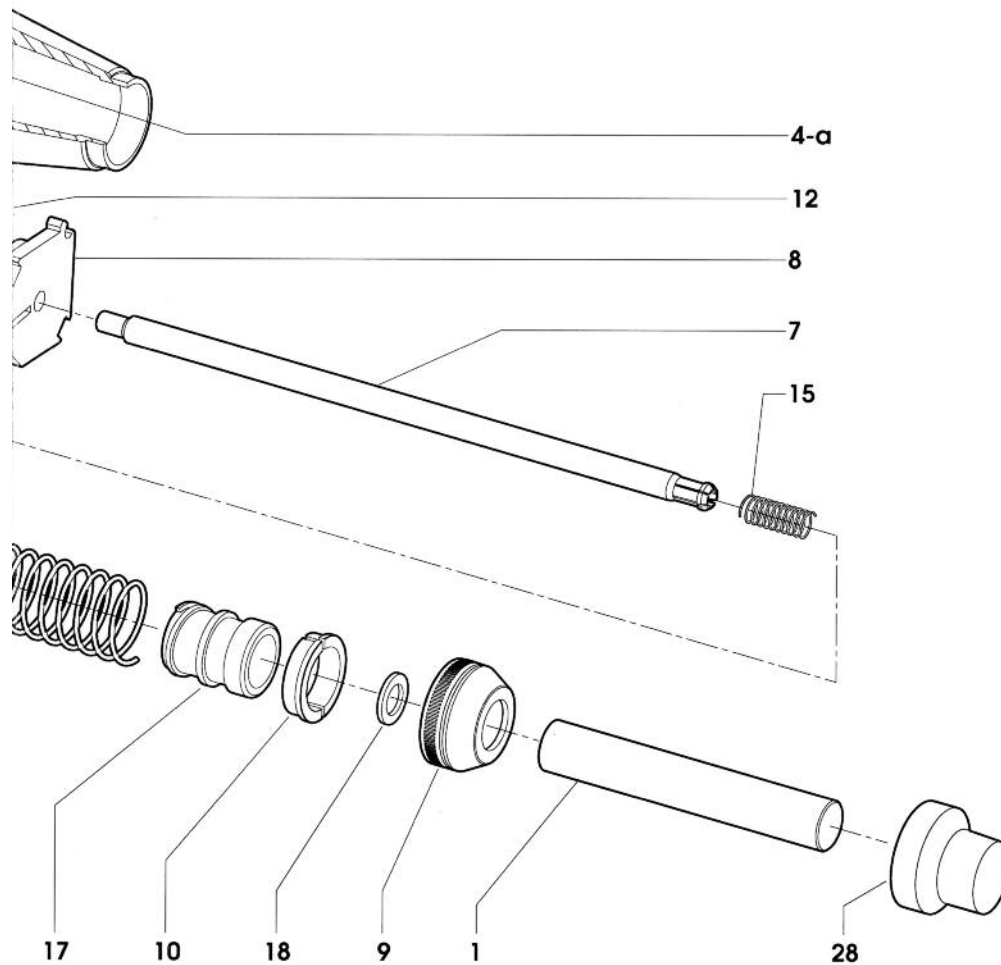
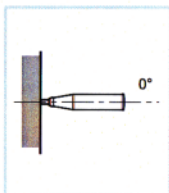
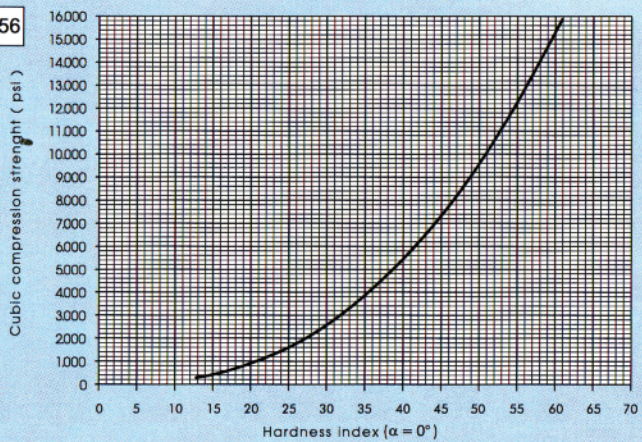

$S^2 = 0,9484$

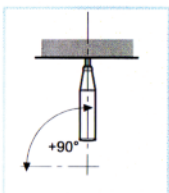
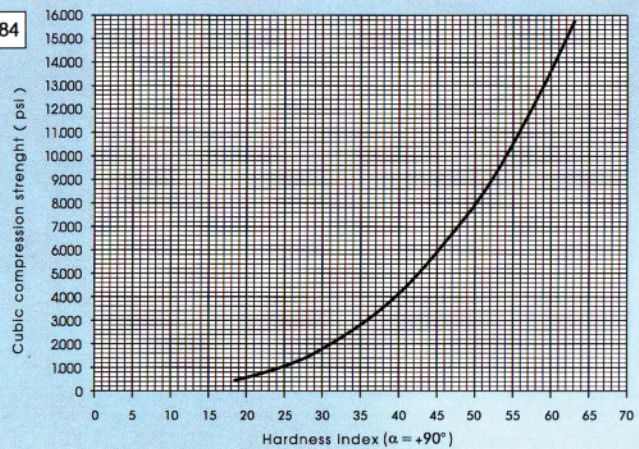

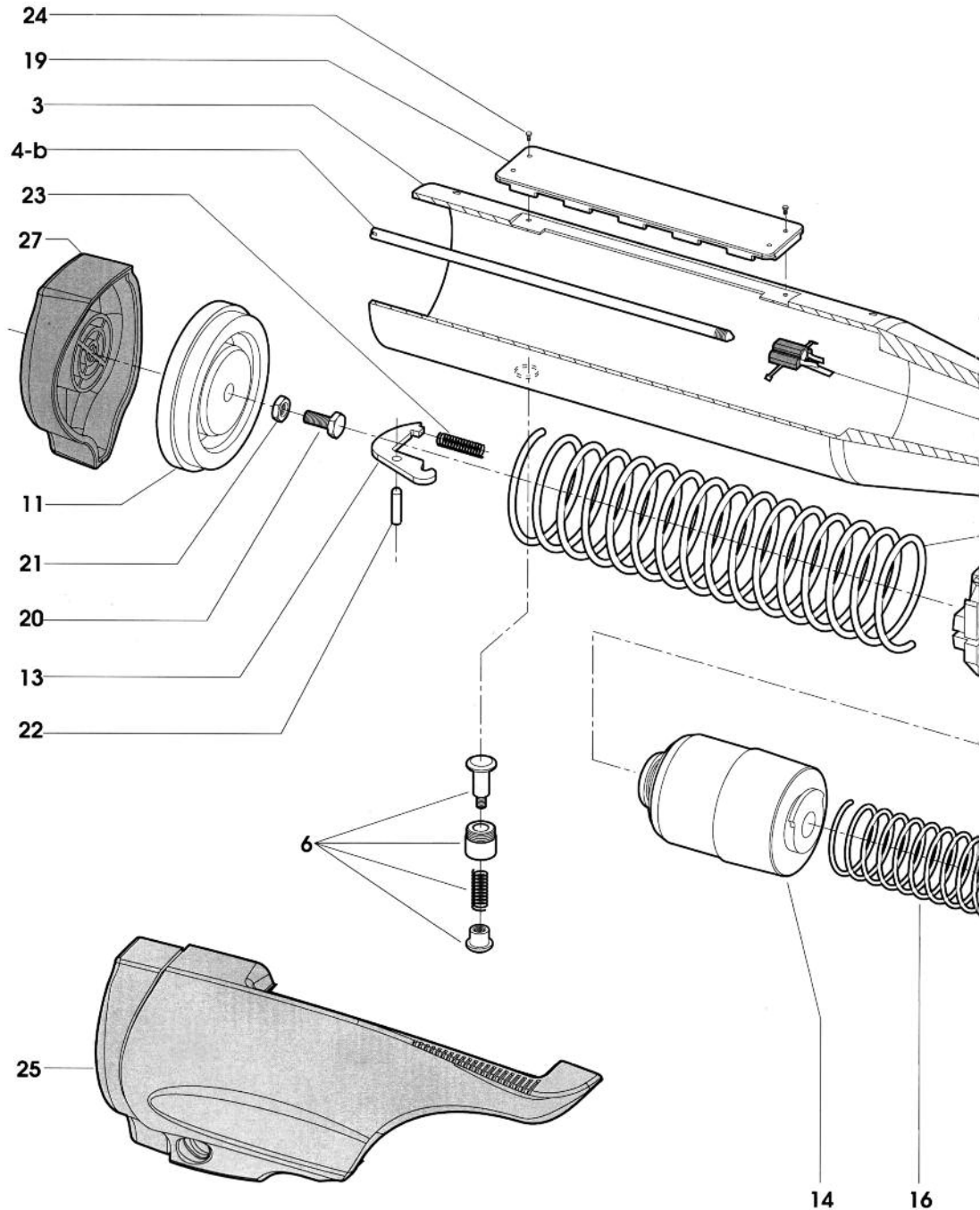

1. Instructions

The following use manual contains safety standards as well as all the necessary instructions for the use of test hammer and the successive elaboration of the data obtained.

To obtain the maximum advantage of the use of the instrument it is recommended that all the instructions have to read thoroughly and with most attention.

The series number and the calibration label are located on the external surface of the body (see the exploded view on the cover).

The present manual is an integral and essential part of the product. It should be preserved with care for the whole life of the instrument. At such time as the manual is lost for reasons unknown to Novatest, the new copy may be purchased separately.

Always inform the data noted below when contacting a Novatest representative or assistance laboratories.

Model:	
Series Number:	
Date of the first calibration check:	

2. General Safety Norm

To prevent the risk of damaging the equipment or cause damages to the operator or third parties, carefully read the following general safety standards prior to using the test hammer. These norms should always be provided with the instrument, so that it may be consulted at any time by the user/operator.

The manufacturer will not assume any responsibility for direct or indirect damages to persons, objects or domestic and non-domestic animals, due to the non-compliance of the safety norms contained in the present documentation.

- The instrument must be used by trained

personnel, in order to avoid the improper use of the equipment.

- The instrument must be used for its destined use for which it was designed.
- The tampering and modification of the instrument is to be considered as negligent and raise the manufacturer from any responsibility deriving from the misuse. In such a situation the guarantee for eventual spare parts or calibration verification will immediately cease to exist.
- Do not perform or carry out any type of test with the instrument on any body part of person/s or animal/s: permanent damage and even grievous bodily harm may be caused by the use of the instrument on certain parts of the human/animal body.

3. Reference Standards

The CONCRETO N test hammer and the calibration anvil SINT03, manufactured by Novatest have been constructed in order to operate within the guidelines set by the standard in-force which regulates the test hammer examination, in particular:

UNI EN 12504-2: 2001

4. Aim and limitations of the test hammer examinations and fields of application

The tests that may be performed on hardened concrete in operation, normal and pre-compressed reinforced concrete, in order to control the quality and estimate the mechanical characteristics the tests are divided into destructive and non-destructive tests.

The "mechanical" method for the determination of the surface hardness via the use of the test hammer is among the non-destructive tests.

This method is based on the corresponding existence between the unitary load

for compression breakage and the surface hardness of the conglomerate, by measuring the remaining elastic Energy (rebound method).

The hammer tests are used to estimate, with due limitations in the procedure, the compression resistance of the concrete in previously constructed structures. In fact the UNI EN 12504-2:2001 at point 1, note 2, prescribes that the test method is not intended as an alternative for the determination of the resistance to compression of the concrete but, with an appropriate correlation, may provide an estimate of the resistance on site.

The test hammer index determined by this method may be used for the evaluation of the uniformity of the concrete on site, to delineate the zones or areas of poor quality or deteriorated concrete present in the structures.

5. Test Hammer operating system

The principle for the function of the instrument is that a mass launched from a spring strikes a piston in contact with the surface and the result of the test is expressed in terms of the bouncing distance of the mass.

The equipment is constituted by a mobile mass with a certain initial Energy, which strikes the surface of a concrete mass. There is a redistribution of the initial kinetic following the strike and namely a part is absorbed by the concrete in the form of plastic or permanent deformation energy and another part of the energy is returned to the mobile mass which bounces for a tract in proportion to the remaining energy.

An essential condition for the distribution of such Energy is that the concrete mass is practically in infinite relationship with the mass of the mobile equipment, otherwise a part of the initial Energy, being independent from the relative masses of

the two bodies that will collide, would be transferred to the concrete in the form of kinetic energy. The condition for infinite mass for the concrete is realized by using very small impact masses.

In order to obtain the necessary energy for the impact a spring system is used. The bounce run is determined by the energy of the bounce following the strike with the concrete and by the characteristics of the spring system.

All the test device that are based on the use of the results from the impact energy, must be equipped with a calibration control in that, after prolonged use, the springs modify their elastic constants.

The mechanical test hammer CONCRETO N has an impact Energy of 2.207 N/m. Diverse types and forms of test hammers for the control of various classes of resistance and types of concrete are commercially available.

Each type and shape of test hammer should only be used for the resistance class and concrete type for which it was intended and designed.

The regression curves noted on page 1 are applicable only to the CONCRETO N test hammer manufactured by Novatest S.r.l. Consequently Novatest S.r.l. will not guarantee the validity of the regression curves where other types of test hammers are employed.

6. Calibration Anvil characteristics and verification of test hammer calibration

The stainless steel calibration anvil SINTO3 for the test hammer verification is characterized by a hardness from 52 to 54 HRC (Rockwell Hardness type C), by a mass of 16 kg and a diameter of about 150mm.

The verification of the calibration of an anvil does not guarantee that different test hammers will produce the same results in other points of the hammer scale.

13. Spare parts list

Position N°	Description
1	Percussion beam
3	Shell
4a	Index
4b	Index small beam
6	Pawl
7	Sliding beam
8	Drive disk
9	Ring nut push rod
10	Block segments
11	Rear cup
12	Pressure spring
13	Hook
14	Hammer
15	Shock absorber spring
16	Percussion spring
17	Ring nut spring holder
18	Felt washer
19	Index plate
20	M6x14 TE Screw
21	M6 Bolt
22	Ratchet gear pin
23	Hook spring
24	M1.7x4.5 Screws
25	Right side shell
26	Left side shell
27	Shell closing cap
28	Transport blocking cup
	Wheel center box - upper/lower
	Abrasive grinding wheel
	Measuring station template-distance 30 mm
	Pencil
	Instruction booklet CONCRETO N
	Note book CONCRETO N
	Phenolphthalein pack ml 100
	Padded bag for sclerometer CONCRETO N

See drawing on the cover

14. Guarantee validity

The mechanical organs of the test hammer are guaranteed for 12 months from the date of purchase of the test hammer. The cost of the calibration check and is-

sue of the relative report will be evacuated in according to the condition of the instrument.

The guarantee loses its validity at such time as tampering with/or attempts at opening the instrument is/are verified.

Reproduction of the instrument is prohibited. All rights reserved. Non part of the present operation manual may be reproduced or distributed in any manner, nor photocopy, microfilm or other, without the written consent of Novatest S.r.l.

All the products may be subjected to modification without notice.

YORK
Survey Supply

Follow us!

f York Survey Supply Centre
@York_Survey
@York_Survey

Prospect House, George Cayley Drive,
Clifton Moor, York, England YO30 4XE

Tel: +44 (0) 1904 692723
Fax: +44 (0) 1904 690385
E-Mail: sales@yorksurvey.co.uk
www.yorksurvey.co.uk

Each cubic test, at a maturation of 28 days, is subjected to the following:

- accurate clearing of surfaces via the medium grain abrasive stone in carborundum, in order to avoid that the sides of the sample could present scratches or nests of gravel or rough surface texture. Preventively a check of the surface was performed in order to ensure that it was dry, in order to avoid that it could alter the test result;
- an accurate control of the dimensions and relative weight.

For the measurements only three faces were considered from each sample, excluding in each the concrete casting side.

In order to obtain the results of the hammer rebound as much as possible independent from the operator, a special machine was used which allows for automatic handling of the cubic tests between the plates of a press with a solicitation of 1 N/mm², in order to hold them rigidly in place, impeding any movement during the impact. In this way it was possible to realize nine strikes in sequence for each face, via a video camera and external monitor it was possible to discern the inclination conditions of the instrument at a = -90°, 0° and + 90° (where "a" is the angle that the test hammer axis forms with the horizontal).

- at the crushing of the cubic samples, from the class 60 N/mm² on the 3000 kN press and from the class 65 N/mm² up to the class 100 N/mm² on the 5000 kN press.

A cloud of points were obtained between the superficial hardness and the unit breakage load.

In total 27000 hammer rebounds were performed and 1000 press compression tests were also carried out.

The experimental campaign was entirely performed at the Novatest S.r.l.

The three regression curves obtained by the experimental campaign, noted on page 1, are subdivided by each diverse inclination condition employed by the test hammer.

S²= determining coefficient of the estimated values

$$S^2 = \left[1 - \frac{\sum (R_{ci} - R_{vi})^2}{\sum (R_{ci})^2} \right] \quad (0 < S^2 < 1)$$

$$\sum (R^2_{ci}) - \frac{\quad}{n}$$

where

R_{ci} = is the evaluated experimental resistance (N/mm²),

R_{vi} = is the evaluate resistance with the correlation formula R=a x lb (N/mm²),

n = is the number of samples examined.

When plus (S²) is approximate to the unit then the errors will more likely be minimal.

12. List of equipment supplied with the instrument

The padded covering encompassing the test hammer includes the following:

- Medium grain abrasive stone in carborundum;
- Station template for measuring;
- Phenolphthalein solution at 1% ethyl alcohol for the determination of carbonatization;
- Plaster for mapping the grills for the measuring stations;
- Notes for test remarks;
- Carpenter pencil
- User manual
- Calibration Certificate

In order to verify the calibration of the test hammer, the stainless steel anvil must be placed on a rigid surface.

Operate the instrument at least three times prior to initiating the readings from the calibration anvil, to ensure that the mechanics are operating correctly.

Then, following this procedure, insert the test hammer in the anvil guide ring and carry out a series of strikes (n° > 10).

The average bounce index of the test hammer strikes performed with the test hammer CONCRETO N to the calibration anvil SINT03 must be 80 ± 2. (pict. 4).

7. Selection and preparation of the test surfaces

The concrete elements to be subjected to the test must be at least 100mm in thickness and fixed inside a structure. Smaller sample pieces may be subjected to testing as long as these pieces are rigidly supported.

Areas that contain the presences of gravel nests, flaking, coarse textures or other porous elements and in the proximity of significant inertia must be avoided. It should also be avoided, by performing a preliminary rebar investigation, the carrying out of test hammer strikes in areas of passing armatures and near of pre-compression cables and wires.

In the selection of an area to be subjected to the test the following factors should be considered:

- identification of the areas interested in the passage of armature;
- type of surface;
- status of the surface humidity;
- carbonatization;
- movement of the concrete during the test;
- evaluation of the damage level of the surface subject to the test;
- test direction;
- other appropriate factors as, for example, the type of concrete and the

declared resistance class.

The area to be subjected to the test must be approximately 300 mm x 300 mm.

Ensure that the distance between the two points of impact are not less than 25 mm and that neither is less than 25 mm from the edge.

The preparation of the test is carried out using an abrasive medium grain carborundum stone, provided with the instrument, to rectify the surfaces with rough or tender textures or surfaces with traces of mortar, in order to render the surfaces smooth. (pict. 2).

The smooth or float surfaces may be subjected to testing without rectification.

Remove eventual water residue present on the cement surface.

8. Performing the Test

Unscrew the safety cap upon removing the test hammer from its covering, lightly push the percussion rod inwards, compressing it towards a rigid surface. The rod will unhook and exit from the instrument body which is now ready for the test.

Operate the instrument at least three times prior to taking any readings, in order to ensure that the mechanics are operating correctly.

In order to facilitate the testing an appropriate station-template supplied with the instrument permits the marking of a normal line grid, with lines distancing from 25 to 50 mm and the intersection of the lines as examination points, on the element subject to the test. (pict. 3).

Depress the percussion rod against the concrete surface under examination, maintaining the apparatus in perpendicular to the surface.

Apply gradual to increasing pressure until the hammer unhooks. Maintain the apparatus firmly pressed against the examined surface, depress the halt pawl and read the value of the rebound index.

Do not touch the halt pawl while pressing the percussion rod. Prior to carrying out a sequence of test sit is best to perform a hammer calibration using the stainless steel anvil of reference and check that it conforms to the limits recommended by the manufacturer (the average rebound index of the hammer strikes performer with the CONCRETO N to the calibration anvil must be 80 ± 2). On the contrary contact the Novatest assistance laboratories.

The test hammer should be used at a temperature between 10°C to 35°C . After the impact record the test hammer index.

Employ a minimum of nine measures in order to obtain a reliable estimate of the test hammer index of a test area. Record the position and the orientation of the test hammer for each measurement.

Examine all the prints left on the surface after the impact and if the impact has shattered or perforated due to a gap near the surface, discard the result.

After the tests, re-perform the test hammer calibration check using the testing steel anvil SINTO3. If the result does not conform to the limits recommended by the manufacturer, annul the test and contact the Novatest assistance laboratories. Humidity, carbonatization alterations, chimica aggressions, micro-cracks, composition and history of the concrete, status of the scabrous surface and underlying mass object of the percussion, are all elements that influence the bounce index value.

A correctly proportioned concrete presents a highly alkaline (pH13) environment which inhibits the oxidization reactions of the armature.

The concrete is however permeable therefore the carbon dioxide may distribute within reacting with the substances that it encounters living way to the phenomenon of carbonatization (environment pH9) and to dimensional variations

that determine the concrete cracks. The cracking sustains the penetration of both carbon dioxide and water vapor which in turn triggers another process: the oxidization of the armature bars/rods, with notable effects.

The concrete altered by the carbonatization will cause an over-estimation of the resistance which in extreme cases may reach 50% (in effect the formation of calcium carbonate cause an hardening of the surface layer).

The presence of the carbonatization may be ascertained via a colorimetric test. The test is normally carried out by spraying (using a sprinkler) on the lateral surface of the cylindrical micro-samples, entracte via coring the elements subject to the test, with a phenolphthalein solution at 1% of ethyl alcohol (supplied with the instrument). The solution undergoes a color change once it is sprinkled going from a transparent white to a red-violet color when the surface results as not carbonatated; on the contrary where a surface is carbonatated the solution does not change remaining its transparent white color. It is possible to establish a correction factor of the readings obtained take into consideration the carbonatization phenomom by comparing the hammer test results carried out on both the carbonatated surface and non-carbonatated below surface area.

9. Test Results

If over 20% of all the measures fluctuates from the average by more than 6 units, the entire set of measurements taken will have to be discarded.

10. Test Report

The test report should include the following:

- a) identification of the element/concrete structure;
- b) position of the test area/s;

- c) test hammer identification;
- d) description of the test area/s preparation;
- e) concrete details and conditions;
- f) date and hour of the test run;
- g) test result (average value) and orientation of the test hammer for each test area;
- h) eventual deviations from the standardized test method;
- i) declaration of the person responsible for the test, whom can attest that the 12504-2:2001 test has been performed, excepting that referred to in point (h).

Where necessary, the report may also include the single test hammer readings.

11. Regression curves obtained by the experimental campaign

A correct application of the test hammer method would theoretically require the mapping of correlation curves with reference to the material in operation. But as this operation is not practicable, above all with the objective difficulty of not knowing the manufacturer of the conglomerate, especially for non-recent structure, we can only limit the mapping of the regression curves based on the pre-packaged tests of available concrete, in the best hypothesis the concrete in use has same characteristics as that used in structures or at least analogous in composition. As for the rest the concrete resistance may be approximately estimated only in the presence of an experimental calibration curve which correlates the resistance of that concrete to the bounce index. In the absence of this estimate then a more general curve may be used which is supplied as support by the test hammer manufacturer.

In this content an experimental campaign has been developed with reference to non-structural, ordinary, high performance and high resistance (from 5 N/mm^2 to 100 N/mm^2), conglomerates, ob-

taineable by preparing particular ingredients and mix-design realizations.

The mapping of the correlation curves has been obtained by simultaneously subjecting a total of 1000 samples to non destructive (determination of the rebound value) and destructive tests (crushing on the press) 50 test of cubic samples with sides of 200 mm by the 20 classes distinguished by the conglomerate as in table 1.

Table 1

CLASS	N° of TESTS	RESISTANCE CLASS (N/mm ²)	CONCRETE CATEGORY
1	50	C5	Non structural
2	50	C10	
3	50	C15	
4	50	C20	Ordinary
5	50	C25	
6	50	C30	
7	50	C35	
8	50	C40	
9	50	C45	
10	50	C50	
11	50	C55	High performances
12	50	C60	
13	50	C65	
14	50	C70	
15	50	C75	High resistance
16	50	C80	
17	50	C85	
18	50	C90	
19	50	C95	
20	50	C100	

The various resistance classes obtained have been produced according to opportune mixes, using Portland cement and an assortment of inertias so as to represent typical standards for Italian concretes.

The samples used in the experimental campaign were in the ideal conditions as required by the test hammer method for the realization of correlation curves. In fact:

- maturation period: 28 days;
- relative humidity aspect: constant (not greater than 65%);
- homogeneity of the concrete quality between the surface and deeper layers;
- carbonatization phenomenon of the superficial layers: absent;
- internal defects: absent.